

Wire Define

Pin 1 (black)	motor -
Pin 2 (red)	motor +
Pin E (green)	GND

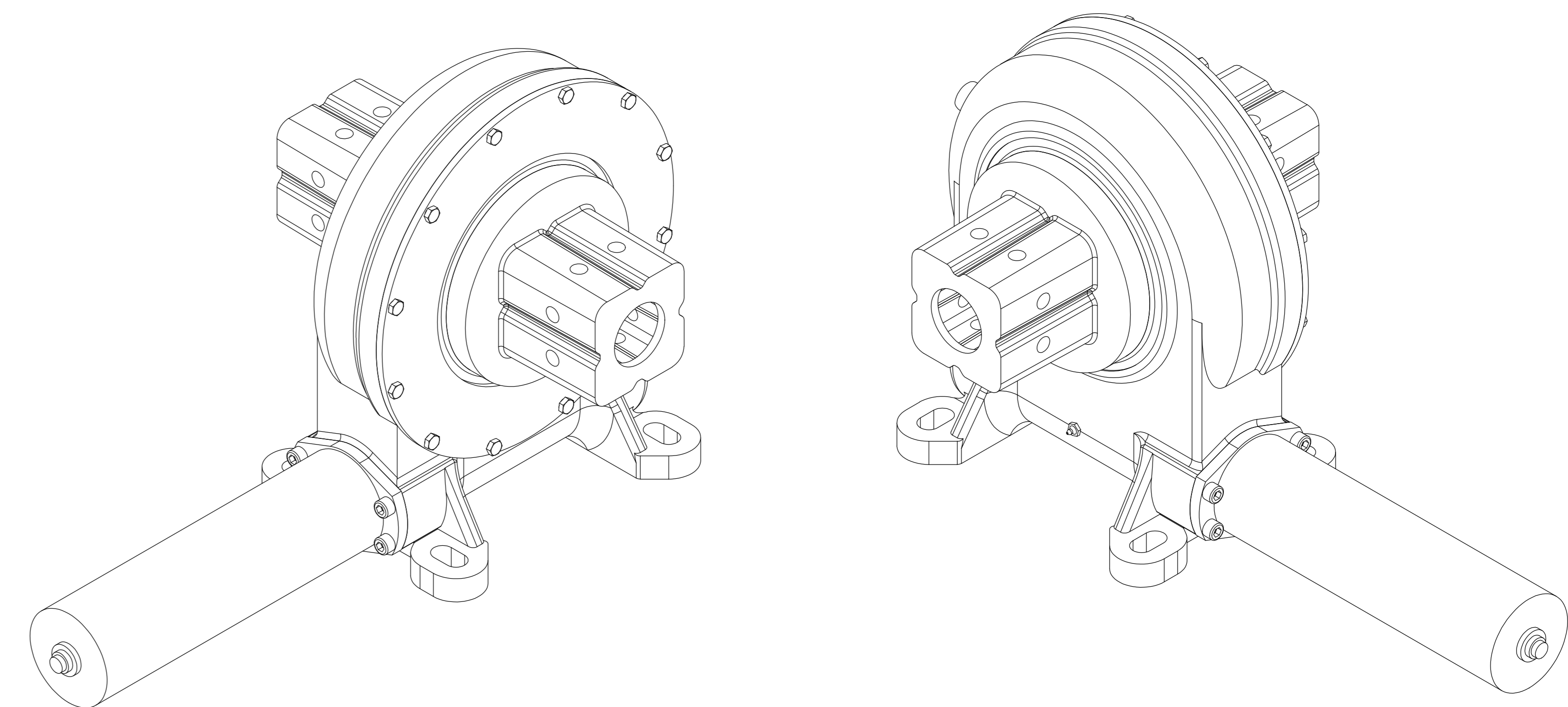

Slewing Drive Performance Parameters	
Rated Output Speed	0.025 rpm
Rated Output Torque	6405 N.m
Tilting Moment	12 kN.m
Holding Torque	58 kN.m
Static Axial Rating	338 kN
Static Radial Rating	120 kN
Dynamic Axial Rating	81 kN
Dynamic Axial Rating	61 kN
Corrosion Protection	C3
Temperature	-30°C~+70°C
Gear Ratio	61 : 1
Hard Limit	±60°
Precision	≤ 0.2°
24VDC Planetary Reducer Motor Performance Data	
Rated Output Torque	300 N.m
Rated Output Speed	1.5 rpm
Rated Current	≤6.5 A
IP Class	IP 65



ALL PROPRIETARY RIGHTS IN THE SUBJECT MATTER HERE OF ARE RESERVED, AND NO PERMISSION IS GRANTED OR TO DISCLOSE REPRODUCE THIS PRINT IN WHOLE OR IN PART, ANY OF THE INFORMATION TO OTHERS.

WEIGHT	SCALE
65Kg	1 : 5
SIZE	A3
SHEET	1 / 1

SYMBOLS ISO

Obrotnica solarna supraBox solar  
9H z silnikiem DC 24V IP65

Cable  
1m